

TestMate® Series

TWS-C TestMate® Water Sensor

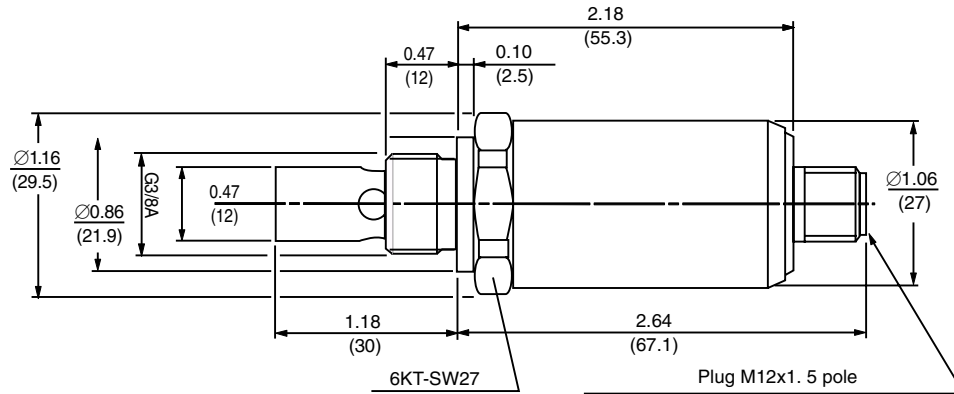

Metric dimensions in ().

Description

The TWS-C is a saturation and temperature sensor for the monitoring of hydraulic and lubrication fluids accurately, continuously and on-line. It measures the water content relative to the saturation concentration (saturation point) and outputs the degree of saturation (saturation level) in the range of 0 to 100% as a 4 to 20 mA signal. A reading of 0% would indicate the absence of water, while a reading of 100% would indicate that a fluid is saturated with water.

The special capacitance sensor used in the TWS absorbs water molecules from the fluid and changes its capacity value that is directly related to the saturation level in the fluid. An integrated thermoelement on the sensor measures the temperature of the fluid in the range of -13°F to 212°F (-25°C to 100°C) and outputs it as a 4 to 20 mA signal.

Features

- Compatible with hydraulic, lube oils and esters
- Measures and displays saturation and temperature continuously
- Displays saturation level in percentage (0% indicates oil is dry; 100% indicates oil is saturated)
- Data can be monitored to PC, PLC, etc.

Applications

- Hydraulic systems that are sensitive to water in oil
- Gear boxes
- Injection molding machines
- Turbines
- Transformers

Desired Saturation Level

Since the effects of free (also emulsified) water is more harmful than those of dissolved water, water levels should remain well below the saturation point. However, even water in solution can cause damage and therefore every reasonable effort should be made to keep saturation levels as low as possible. There is no such thing as too little water. As a guideline, we recommend maintaining saturation levels below 45% in all equipment.

The TWS-C is individually calibrated on computer-controlled test rigs and subjected to a final test and will operate perfectly when used according to the specifications.

If you have any questions regarding technical details or the suitability of the TWS-C for your application, please contact our sales/technical department.

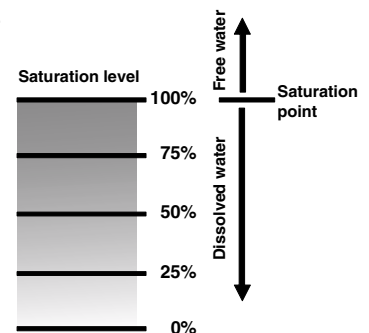

TestMate® Series

Input Data:	Measuring Range:	0 to 100% Saturation; -13°F to 212°F (25°C to 100°C)
	Operating Pressure:	725 psi (50 bar) max
	Overload Pressure:	9135 psi (630 bar) max
	Parts in Contact with Media:	Stainless steel, seal Viton or EPR Ceramic with evaporated metal
Output Data:	<i>Humidity Measurement:</i>	
	Output Signal (saturation level):	4 to 20 mA
	Calibrated Accuracy:	≤ ± 2% FS max
	Accuracy in Media Measurements:	≤ ± 3% FS typ.
	Pressure-dependent:	+ 0.02% FS/bar
Output Data:	<i>Temperature Measurement:</i>	
	Output Signal (temperature):	4 to 20 mA
	Accuracy:	± 2% FS max
Ambient Conditions:	Nominal Temperature Range (saturation level measuring):	32°F to 194°F (0°C to 90°C)
	Ambient Temperature Range:	-40°F to 212°F (-40°C to 100°C)
	Fluid Temperature Range:	-40°F to 257°F (-40°C to 125°C)
	Viscosity Range:	32 to 23,175 SUS (1 to 5000 cSt)
	Flow Velocity:	< 16 ft/s
	Media Tolerance:	Mineral oil-based fluids, natural and synthetic esters
	CE Mark:	EN 50081-1, EN 50081-2, EN 50082-1, EN 61000-6-2
	Type of Protection acc. DIN 40050:	IP 67
Other Data:	Supply Voltage:	12 to 32 VDC
	Residual Ripple Supply Voltage:	≤ 5%
	Mechanical Connection:	G3/8A DIN 3852
	Torque Rating:	18.5 ft-lbs
	Electrical Connection:	M12x1, 5 pole (DIN VDE 0627)
	Pin 1:	+Ub
	Pin 2:	Signal saturation level
	Pin 3:	0V / GND
	Pin 4:	Signal temperature
	Pin 5:	Not connected

FS (Full Scale) relative to the full measuring range

TestMate® Water Sensor	Type of Medium	Signal Technology	Signal Technology
TWS-C	M = Mineral Oil E = Esters	0 = Saturation Level	0 = Temperature

Preferred order codes designate shorter lead times and faster delivery.

Part Number	Description	Color Code
ZBE 08	(5 pole) Connector M12x1, right-angled	Pin 1: Brown
ZBE 08-02	(5 pole) with 2m cable	Pin 2: White
VDP-177	(5 pole) with 5m cable	Pin 3: Blue
ZBE 08S-02	(5 pole) with 2m screened cable	Pin 4: Black
ZBE 08S-05	(5 pole) with 5m screened cable	Pin 5: Grey
ZBE 08S-10	(5 pole) with 10m screened cable	

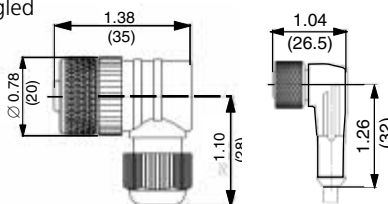

Specifications

- TCM
- TCM-FC
- TMU
- SMART® Kit
- TPM
- TIM
- CTU
- TWS-C**
- ET-100-6
- HMG 3000
- EWC
- EPK
- HTB
- GS
- Trouble Check Plus
- Test Points
- Adapters
- Hose Joiners
- Microflex Hose
- Pressure Limiters
- Pressure Gauges
- Test Kits
- Probalizer
- AFM
- MSS, MDS
- MFS, MFD
- AMS, AMD
- KSS, KSD
- KLS, KLD
- AKS, AKD
- KLC
- X Series
- HFS
- MTS
- SVD
- Appendix

Model Number Selection

Accessories