

# X Series Filter Skids

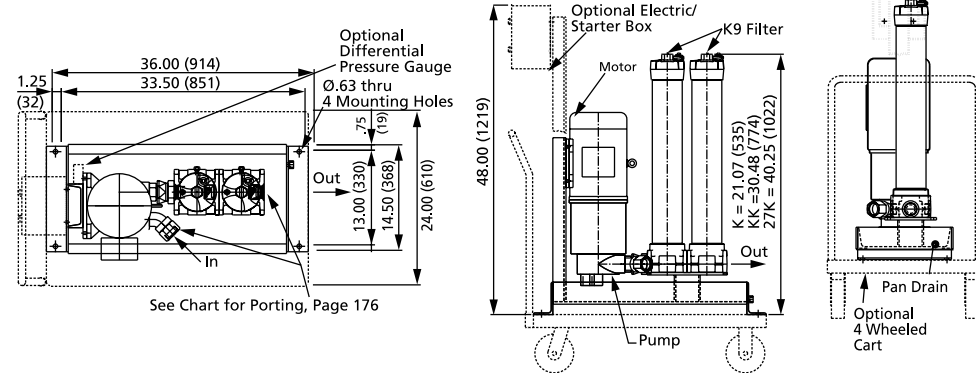

Dual K9 Filter Version (Series X4, X5 and X6)

Metric dimensions in ( ).

## Description

Schroeder's new X Series filtration skids are compact, self-contained filtration systems equipped with high efficiency, high capacity elements capable of removing particulate contamination and/or water quickly and economically. They supplement in-line filters whenever the existing filtration is incapable of obtaining the desired ISO cleanliness level.

It is not uncommon for viscosity to be overlooked when specifying an off-line filtration unit. The results of this oversight can severely affect system efficiency and longevity, and render the filtration system useless when high viscosity fluid causes the filter to be in constant bypass. Schroeder considers maximum fluid viscosity, (at the minimum operating temperature) in conjunction with flow to properly size the pump and motor.

Standard X Series skids include a hydraulic pump, electric motor, and either a single or dual K9 or QF15 housing. Many different component combinations provide the flexibility to match specific system viscosity, flow, and cleanliness requirements. Multiple housing lengths give the option of adding additional dirt holding capacity.

# X Series Filter Skids

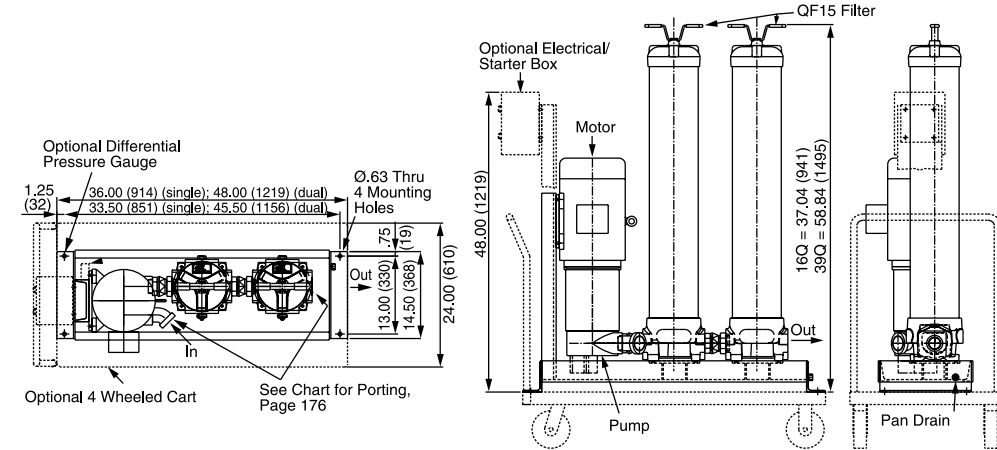

Dual QF15 Filter Version (Series X4, X5 and X6)

Series	Viscosity Range	Filter Housing(s)	Maximum Flow
X1	150 - 500 SUS	(1) QF15 or K9	82 gpm (310 L/min)
X2	500 - 2000 SUS	(1) QF15 or K9	82 gpm (310 L/min)
X3	2000 - 5000 SUS	(1) QF15 or K9	37 gpm (140 L/min)
X4	150 - 500 SUS	(2) QF15 or K9 in series	82 gpm (310 L/min)
X5	500 - 2000 SUS	(2) QF15 or K9 in series	82 gpm (310 L/min)
X6	2000 - 5000 SUS	(2) QF15 or K9 in series	37 gpm (140 L/min)

## Skid Selection

## Model Number Selection

Skid Series	Flow (gpm)	Filter Designation						Element Media 1st Filter <sup>1,4</sup>	Element Media 2nd Filter <sup>1,4</sup>	Seal Material
		1K	2K	3K	16Q	39Q				
X1	09	1K	2K	3K	16Q	39Q	A = Z1 (K or Q) B = Z3 (K or Q) C = Z5 (K or Q) D = Z10 (K or Q) E = Z25 (K or Q) F = QCLQFZ1 G = QCLQFZ3 H = QCLQFZ5 J = QCLQFZ10 L = QCLQFZ25 M = QPMLZ1 P = QPMLZ3 R = QPMLZ5 S = QPMLZ10 T = QPMLZ25 W = W	N = NA A = Z1 (K or Q) B = Z3 (K or Q) C = Z5 (K or Q) D = Z10 (K or Q) E = Z25 (K or Q) F = QCLQFZ1 G = QCLQFZ3 H = QCLQFZ5 J = QCLQFZ10 L = QCLQFZ25 M = QPMLZ1 P = QPMLZ3 R = QPMLZ5 S = QPMLZ10 T = QPMLZ25 W = W	B = Buna (Standard) H = EPR V = Viton	
	17	1K	2K	3K	1Q	3Q				
	37	1K	2K	3K	1Q	3Q				
	82	1K	2K	3K	1Q	3Q				
X2 <sup>1</sup>	09	1K	2K	3K	16Q	39Q	A = Z1 (K or Q) B = Z3 (K or Q) C = Z5 (K or Q) D = Z10 (K or Q) E = Z25 (K or Q) F = QCLQFZ1 G = QCLQFZ3 H = QCLQFZ5 J = QCLQFZ10 L = QCLQFZ25 M = QPMLZ1 P = QPMLZ3 R = QPMLZ5 S = QPMLZ10 T = QPMLZ25 W = W	N = NA A = Z1 (K or Q) B = Z3 (K or Q) C = Z5 (K or Q) D = Z10 (K or Q) E = Z25 (K or Q) F = QCLQFZ1 G = QCLQFZ3 H = QCLQFZ5 J = QCLQFZ10 L = QCLQFZ25 M = QPMLZ1 P = QPMLZ3 R = QPMLZ5 S = QPMLZ10 T = QPMLZ25 W = W	B = Buna (Standard) H = EPR V = Viton	
	17	1K	2K	3K	1Q	3Q				
	37	1K	2K	3K	1Q	3Q				
	82	1K	2K	3K	1Q	3Q				
X3 <sup>2</sup>	09	1K	2K	3K	16Q	39Q	A = Z1 (K or Q) B = Z3 (K or Q) C = Z5 (K or Q) D = Z10 (K or Q) E = Z25 (K or Q) F = QCLQFZ1 G = QCLQFZ3 H = QCLQFZ5 J = QCLQFZ10 L = QCLQFZ25 M = QPMLZ1 P = QPMLZ3 R = QPMLZ5 S = QPMLZ10 T = QPMLZ25 W = W	N = NA A = Z1 (K or Q) B = Z3 (K or Q) C = Z5 (K or Q) D = Z10 (K or Q) E = Z25 (K or Q) F = QCLQFZ1 G = QCLQFZ3 H = QCLQFZ5 J = QCLQFZ10 L = QCLQFZ25 M = QPMLZ1 P = QPMLZ3 R = QPMLZ5 S = QPMLZ10 T = QPMLZ25 W = W	B = Buna (Standard) H = EPR V = Viton	
	17	1K	2K	3K	1Q	3Q				
	37	1K	2K	3K	1Q	3Q				
	82	1K	2K	3K	1Q	3Q				
X4	09	1K	2K	3K	16Q	39Q	A = Z1 (K or Q) B = Z3 (K or Q) C = Z5 (K or Q) D = Z10 (K or Q) E = Z25 (K or Q) F = QCLQFZ1 G = QCLQFZ3 H = QCLQFZ5 J = QCLQFZ10 L = QCLQFZ25 M = QPMLZ1 P = QPMLZ3 R = QPMLZ5 S = QPMLZ10 T = QPMLZ25 W = W	N = NA A = Z1 (K or Q) B = Z3 (K or Q) C = Z5 (K or Q) D = Z10 (K or Q) E = Z25 (K or Q) F = QCLQFZ1 G = QCLQFZ3 H = QCLQFZ5 J = QCLQFZ10 L = QCLQFZ25 M = QPMLZ1 P = QPMLZ3 R = QPMLZ5 S = QPMLZ10 T = QPMLZ25 W = W	B = Buna (Standard) H = EPR V = Viton	
	17	1K	2K	3K	1Q	3Q				
	37	1K	2K	3K	1Q	3Q				
	82	1K	2K	3K	1Q	3Q				
X5 <sup>1</sup>	09	1K	2K	3K	16Q	39Q	A = Z1 (K or Q) B = Z3 (K or Q) C = Z5 (K or Q) D = Z10 (K or Q) E = Z25 (K or Q) F = QCLQFZ1 G = QCLQFZ3 H = QCLQFZ5 J = QCLQFZ10 L = QCLQFZ25 M = QPMLZ1 P = QPMLZ3 R = QPMLZ5 S = QPMLZ10 T = QPMLZ25 W = W	N = NA A = Z1 (K or Q) B = Z3 (K or Q) C = Z5 (K or Q) D = Z10 (K or Q) E = Z25 (K or Q) F = QCLQFZ1 G = QCLQFZ3 H = QCLQFZ5 J = QCLQFZ10 L = QCLQFZ25 M = QPMLZ1 P = QPMLZ3 R = QPMLZ5 S = QPMLZ10 T = QPMLZ25 W = W	B = Buna (Standard) H = EPR V = Viton	
	17	1K	2K	3K	1Q	3Q				
	37	1K	2K	3K	1Q	3Q				
	82	1K	2K	3K	1Q	3Q				
X6 <sup>2</sup>	09	1K	2K	3K	16Q	39Q	A = Z1 (K or Q) B = Z3 (K or Q) C = Z5 (K or Q) D = Z10 (K or Q) E = Z25 (K or Q) F = QCLQFZ1 G = QCLQFZ3 H = QCLQFZ5 J = QCLQFZ10 L = QCLQFZ25 M = QPMLZ1 P = QPMLZ3 R = QPMLZ5 S = QPMLZ10 T = QPMLZ25 W = W	N = NA A = Z1 (K or Q) B = Z3 (K or Q) C = Z5 (K or Q) D = Z10 (K or Q) E = Z25 (K or Q) F = QCLQFZ1 G = QCLQFZ3 H = QCLQFZ5 J = QCLQFZ10 L = QCLQFZ25 M = QPMLZ1 P = QPMLZ3 R = QPMLZ5 S = QPMLZ10 T = QPMLZ25 W = W	B = Buna (Standard) H = EPR V = Viton	
	17	1K	2K	3K	1Q	3Q				
	37	1K	2K	3K	1Q	3Q				
	82	1K	2K	3K	1Q	3Q				

1. Z1 media not offered for use in 500 to 2000 SUS filtration skids. Contact factory for specific applications.  
 2. Z1 and Z3 media not offered for use in 2000 to 5000 SUS filtration skids. Contact factory for specific applications.  
 3. All elements are singular construction (no stacked elements)  
 4. QPML and QCLZ coreless elements only available in the QF15 housing.

Power	Motor Frame	Starter Control Options <sup>5,6</sup>	Dirt Alarm	Vacuum Gauge	Miscellaneous Options
A = 115 VAC <sup>8</sup> 1.5 hp (Available only with 109, 209, and 309)	N = TEFC  W = Washdown (NEMA Design B)	N = None  A = 230 VAC  B = 460 VAC  C = 230 VAC (with VFD)  D = 460 VAC (with VFD)  E = 575 VAC  F = 575 VAC (with VFD)	N = Cartridge in Cap (Standard)  G = Differential Pressure Gauge  M = MS11 <sup>5,6</sup> Electric Cartridge  C = Differential Pressure Gauge with Electric Switch <sup>5,6</sup>	N = None  V = Vacuum Gauge	N = None  S = Suction Strainer  C = 4 Wheeled Cart  B = Continuous Bleed <sup>7</sup>  P = SMART <sup>®</sup> Kit <sup>10</sup>

5. Motor starter control option - C-series, non-disconnect shut-off, "motor on" light, electrical indicator "change element" light, and type 4x wash down enclosure.  
 6. VFD control option - same as above but with enclosed variable frequency drive control and larger metal NEMA enclosure.  
 7. Continuous bleed option - to eliminate filter air buildup in continuously aerated systems. Includes cap vent port, valve, and return line.  
 8. 115 VAC power option includes switch, 10' cord, and plug. For 1.5 hp motors only.  
 9. 575 will be built to CSA standards.  
 10. Only available on X1 and X4.



- TCM
- TCM-FC
- TMU
- SMART<sup>®</sup> Kit
- TPM
- TIM
- CTU
- TWS-C
- ET-100-6
- HMG 3000
- EWC
- EPK
- HTB
- GS
- Trouble Check Plus
- Test Points
- Adapters
- Hose Joiners
- Microflex Hose
- Pressure Limiters
- Pressure Gauges
- Test Kits
- Probalizer
- AFM
- MSS, MDS, MFS, MFD
- AMS, AMD
- KSS, KSD, KLS, KLD
- AKS, AKD
- KLC
- X Series**
- HFS
- MTS
- SVD
- Appendix

# X Series Filter Skids

## Specifications

<b>Flow Rating:</b>	Up to 82 gpm (310 L/min)
<b>Temp. Range:</b>	-20°F to 225°F (-29°C to 107°C)
<b>Bypass Valve Setting:</b>	50 psi (3.5 bar) for skid series X1, X2, X3, X4, and X5 40 psi (2.8 bar) for skid series X6
<b>Fluid Viscosity:</b>	Up to 5000 SUS (see Skid Selection; previous page)
<b>Compatibility:</b>	All petroleum based hydraulic fluids. Contact Schroeder for use with other fluids, including ester and skydrol
<b>Pump:</b>	Continuous duty gear pump with integral 150 psi relief. Flow dependent on skid series and motor. Refer to table below.
<b>Motor:</b>	Horsepower dependent on skid series and flow. Refer to table below.
<b>Porting:</b>	Dependent on flow. Refer to table below.

## Pump and Motor Data

Skid Series	Flow (gpm)	Motor (hp)	Skid Series	Flow (gpm)	Motor (hp)
X1	09	1.5	X4	09	2
	17	3		17	3
	37	5		37	5
	82	10		82	10
X2	09	1.5	X5	09	2
	17	3		17	5
	37	5		37	10
	82	10		82	15
X3	09	1.5	X6	09	2
	17	5		17	5
	37	10		37	10

## Porting Data

Flow (gpm)	Inlet Port Sizes	Outlet Port Sizes with K9 & MK9 Filters	Outlet Port Sizes with QF15 Filters
09	1.625-12UN-2B SAE O-Ring Boss	1.312-12UN-2B SAE O-Ring Boss	1.625-12UN-2B SAE O-Ring Boss
17	1.875-12UN-2B SAE O-Ring Boss	1.625-12UN-2B SAE O-Ring Boss	1.625-12UN-2B SAE O-Ring Boss
37	2" JIC	1.875-12UN-2B SAE O-Ring Boss	1.875-12UN-2B SAE O-Ring Boss
82	2" JIC	1.875-12UN-2B SAE O-Ring Boss	2.500-12UN-2B SAE O-Ring Boss

## Weight Data

Skid Series	Flow (gpm)	Weight (lb)*	Skid Series	Flow (gpm)	Weight (lb)*
X1	09	238-357	X4	09	372-442
	17	300-504		17	353-662
	37	329-577		37	398-791
	82	476-705		82	551-904
X2	09	238-357	X5	09	301-442
	17	311-504		17	396-684
	37	348-577		37	497-849
	82	597-705		82	947-1054
X3	09	238-479	X6	09	267-650
	17	340-580		17	370-659
	37	461-566		37	502-607

\*Weight dependent on options chosen.

## Features

- Protects and extends the life of expensive components
- Minimizes downtime and maintenance costs
- Designed to handle high viscosity oils up to 5,000 SUS (see Skid Selection; previous page)
- Many component combinations and variable starter options allow the flexibility to match specific user needs
- Four wheel cart option provides product portability
- Integral drip pan with drain plug
- Sample valves provided at filter base for fluid sampling
- Market leading Schroeder Excellement® synthetic filtering media provides for quick, efficient clean up with maximum element life
- Availability of all plastic, environmentally friendly, coreless elements for QF15 housings

# X Series Filter Skids - High Viscosity

Schroeder's new high viscosity X Series skids are compact, self-contained filtration systems. They are designed to handle fluids that have a viscosity as high as 25,000 SUS. The skids have 39" long QF15 filters to efficiently clean the viscous fluids. The filters have a high dirt-holding capacity, capable of holding almost 1000 grams of dirt depending on the element.

Standard high viscosity X Series skids include a pump, motor, QF15 filter, suction strainer, and dirt indicator. Various options can account for specific user needs.

## Description

## Specifications

<b>Flow Rating:</b>	6 gpm or 30 gpm
<b>Temperature Rating:</b>	0°F to 180°F (-17°C to 82°C)
<b>Bypass Valve Setting:</b>	50 psi (3.4 bar)
<b>Fluid Viscosity:</b>	100 SUS to 25,000 SUS
<b>Compatibility:</b>	Hydraulic and lubricating fluids
<b>Pump:</b>	Positive displacement rotary screw pump
<b>Motor:</b>	230/460 VAC 3 phase motor. Horsepower dependent on skid series
<b>Porting:</b>	Inlet and outlet ports are 1.5" (1.875-12) MJIC ports

- Protects and extends the life of expensive components
- Designed to handle high viscosity oils up to 25,000 SUS
- 39" long Q15 filters included to clean high viscosity fluids
- Suction strainer and built-in relief valve included to protect pump
- Integral drip pan with drain plug prevents oil from dripping on the ground, thereby providing a safer environment
- Sample valves provided at the filter base for fluid sampling

## Features

Skid Series	Element Media 1st	Element Media 2nd	Seal Material	Motor Frame	Starter Control Options	Dirt Alarm	Miscellaneous Options
X7 = 6 gpm	C = Z5	C = Z5	B = Buna	N = TEFC	N = None	N = Cartridge in Cap (Standard)	N = None
		D = Z10					
		E = Z25					
X8 = 30 gpm	D = Z10	X = Not Available*	B = Buna V = Viton	W = Washdown	A = 230 VAC B = 460 VAC C = 230 VAC with VFD D = 460 VAC with VFD E = 575 VAC F = 575 VAC with VFD	G = Differential Pressure Gauge M = MS11 Electric Cartridge C = Differential Pressure Gauge with Electric Switch	C = 4 Wheeled Cart D = Continuous Bleed V = Vacuum Gauge
		E = Z25					
		X = Not Available*					

\*The X7 skid allows for one filter or two filters in series.

\*\*The X8 skid will have two QF15 filters in parallel, but both will have the same element type.

This information relates to the operating conditions and applications described. For applications or operating conditions not described, please contact the relevant technical department. Subject to technical modifications.

## Model Number Selection

- TCM
- TCM-FC
- TMU
- SMART® Kit
- TPM
- TIM
- CTU
- TWS-C
- ET-100-6
- HMG 3000
- EWC
- EPK
- HTB
- GS
- Trouble Check Plus
- Test Points
- Adapters
- Hose Joiners
- Microflex Hose
- Pressure Limiters
- Pressure Gauges
- Test Kits
- Probalizer
- AFM
- MSS, MDS, MFS, MFD
- AMS, AMD
- KSS, KSD, KLS, KLD
- AKS, AKD
- KLC
- X Series**
- HFS
- MTS
- SVD
- Appendix

# X Series Filter Skids

## Specifications

<b>Flow Rating:</b>	Up to 82 gpm (310 L/min)
<b>Temp. Range:</b>	-20°F to 225°F (-29°C to 107°C)
<b>Bypass Valve Setting:</b>	50 psi (3.5 bar) for skid series X1, X2, X3, X4, and X5 40 psi (2.8 bar) for skid series X6
<b>Fluid Viscosity:</b>	Up to 5000 SUS (see Skid Selection; previous page)
<b>Compatibility:</b>	All petroleum based hydraulic fluids. Contact Schroeder for use with other fluids, including ester and skydrol
<b>Pump:</b>	Continuous duty gear pump with integral 150 psi relief. Flow dependent on skid series and motor. Refer to table below.
<b>Motor:</b>	Horsepower dependent on skid series and flow. Refer to table below.
<b>Porting:</b>	Dependent on flow. Refer to table below.

## Pump and Motor Data

Skid Series	Flow (gpm)	Motor (hp)	Skid Series	Flow (gpm)	Motor (hp)
X1	09	1.5	X4	09	2
	17	3		17	3
	37	5		37	5
	82	10		82	10
X2	09	1.5	X5	09	2
	17	3		17	5
	37	5		37	10
	82	10		82	15
X3	09	1.5	X6	09	2
	17	5		17	5
	37	10		37	10

## Porting Data

Flow (gpm)	Inlet Port Sizes	Outlet Port Sizes with K9 & MK9 Filters	Outlet Port Sizes with QF15 Filters
09	1.625-12UN-2B SAE O-Ring Boss	1.312-12UN-2B SAE O-Ring Boss	1.625-12UN-2B SAE O-Ring Boss
17	1.875-12UN-2B SAE O-Ring Boss	1.625-12UN-2B SAE O-Ring Boss	1.625-12UN-2B SAE O-Ring Boss
37	2" JIC	1.875-12UN-2B SAE O-Ring Boss	1.875-12UN-2B SAE O-Ring Boss
82	2" JIC	1.875-12UN-2B SAE O-Ring Boss	2.500-12UN-2B SAE O-Ring Boss

## Weight Data

Skid Series	Flow (gpm)	Weight (lb)*	Skid Series	Flow (gpm)	Weight (lb)*
X1	09	238-357	X4	09	372-442
	17	300-504		17	353-662
	37	329-577		37	398-791
	82	476-705		82	551-904
X2	09	238-357	X5	09	301-442
	17	311-504		17	396-684
	37	348-577		37	497-849
	82	597-705		82	947-1054
X3	09	238-479	X6	09	267-650
	17	340-580		17	370-659
	37	461-566		37	502-607

\*Weight dependent on options chosen.

## Features

- Protects and extends the life of expensive components
- Minimizes downtime and maintenance costs
- Designed to handle high viscosity oils up to 5,000 SUS (see Skid Selection; previous page)
- Many component combinations and variable starter options allow the flexibility to match specific user needs
- Four wheel cart option provides product portability
- Integral drip pan with drain plug
- Sample valves provided at filter base for fluid sampling
- Market leading Schroeder Excellement® synthetic filtering media provides for quick, efficient clean up with maximum element life
- Availability of all plastic, environmentally friendly, coreless elements for QF15 housings